

ATASI 3020 OEM MANUAL

Table of Contents

[Table of Contents](#)

[FIGURES: 1 POWER UP SEQUENCE](#)

[CONTROL SIGNALS](#)

[DATA SIGNALS](#)

[TYPICAL CONNECTION, 4 DRIVES](#)

[CONTROL SIGNAL RECEIVER/DRIVER COMBINATION](#)

[STEP MODE TIMING \(NORMAL\)](#)

[STEP MODE TIMING \(BUFFERED\)](#)

[SELECT JUMPER, TERMINATOR AND \)3 LOCATIONS](#)

[INDEX TIMING](#)

[DATA LINE DRIVER/RECEIVER COMBINATION](#)

[MFM ENCODING](#)

[WRITE PRE-COMPENSATION PATTERNS](#)

[READ/WRITE DATA TIMING](#)

[CURRENT REQUIREMENTS](#)

[STARTING CURRENT](#)

[CONNECTOR LOCATIONS](#)

[J1 CONNECTOR DIMENSIONS](#)

[MOUNTING DIMENSIONS](#)

[Other ManualsLib Projects](#)

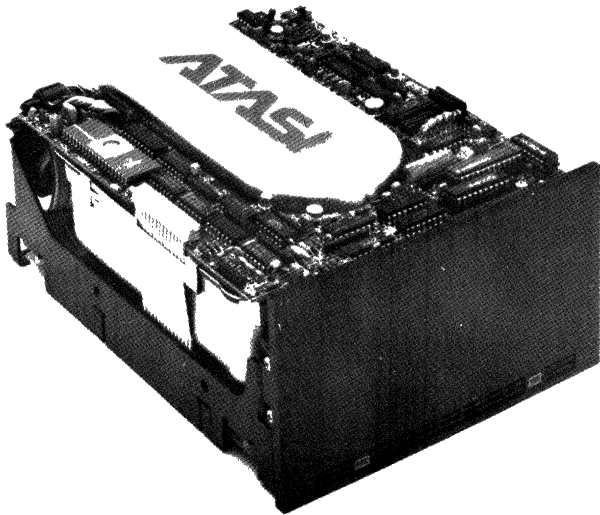

ATASI

SERIES 3000 OEM MANUAL

TABLE OF CONTENTS

1.0 INTRODUCTION	
1.1 GENERAL DESCRIPTION	1
1.2 DEVICE SPECIFICATION	2
1.2.1 ENVIRONMENTAL SPECIFICATIONS	2
1.2.2 RELIABILITY SPECIFICATIONS	2
1.2.3 PERFORMANCE SUMMARY	3
1.2.4 FUNCTIONAL SUMMARY	3
2.0 GENERAL OPERATION	4
2.1 ORGANIZATION	4
2.2 READ/WRITE/INTERFACE PWA	4
2.3 SPINDLE/EMA DRIVE PWA	4
2.4 SERVO CONTROL PWA	4
2.5 SPINDLE DRIVE MECHANISM	5
2.6 AIR FILTRATION SYSTEM	5
2.7 POSITIONING MECHANISM	5
2.8 READ/WRITE HEADS AND MEDIA	5
3.0 FUNCTIONAL OPERATION	6
3.1 POWER SEQUENCING	6
3.2 DRIVE SELECTION	7
3.3 CYLINDER ACCESSING	7
3.4 HEAD SELECTION	7
3.5 READ OPERATION	7
3.6 WRITE OPERATION	7
4.0 ELECTRICAL INTERFACE	8
4.1 CONTROL INPUT LINES	11
4.1.1 -WRITE GATE	11
4.1.2 -HEAD SELECT	11
4.1.3 -DIRECTION IN	12
4.1.4 -STEP	13
4.1.5 -DRIVE SELECT 1-4	13
4.2 CONTROL OUTPUT LINES	13
4.2.1 -SEEK COMPLETE	13
4.2.2 -TRACK 0	14
4.2.3 -WRITE FAULT	14
4.2.4 -INDEX	14
4.2.5 -READY	14
4.3 DATA TRANSFER LINES	14
4.3.1 +/-MFM WRITE DATA	15
4.3.2 +/-MFM READ DATA	16
4.3.3 READ/WRITE TIMING	16

4.4	-DRIVE SELECTED	17
4.5	POWER INTERFACE	18
4.6	CUSTOMER OPTION	18
5.0	PHYSICAL INTERFACE	19
5.1	J1/P1 CONNECTOR — CONTROL SIGNALS	20
5.2	J2/P2 CONNECTOR — DATA SIGNALS	21
5.3	J3/P3 CONNECTOR — DC POWER	22
5.4	J4/P4 FRAME GROUND	22
6.0	PHYSICAL SPECIFICATIONS	23
6.1	MOUNTING ORIENTATION	23
6.2	MOUNTING HOLES	23
6.3	PHYSICAL DIMENSIONS	23
6.4	SHIPPING REQUIREMENTS	23
7.0	SURFACE DEFECTS	25
FIGURES:		
1	POWER UP SEQUENCE	6
2	CONTROL SIGNALS	8
3	DATA SIGNALS	9
4	TYPICAL CONNECTION, 4 DRIVES	10
5	CONTROL SIGNAL RECEIVER/DRIVER COMBINATION	11
6A	STEP MODE TIMING (NORMAL)	12
6B	STEP MODE TIMING (BUFFERED)	12
7	SELECT JUMPER, TERMINATOR AND J3 LOCATIONS	13
8	INDEX TIMING	14
9	DATA LINE DRIVER/RECEIVER COMBINATION	15
10A	MFM ENCODING	15
10B	WRITE PRE-COMPENSATION PATTERNS	16
11	READ/WRITE DATA TIMING	17
12	CURRENT REQUIREMENTS	18
13	+12V STARTING CURRENT	18
14	CONNECTOR LOCATIONS	19
15	J1 CONNECTOR DIMENSIONS	20
16	J2 CONNECTOR DIMENSIONS	21
17	J3 CONNECTOR LAYOUT	22
18	MOUNTING DIMENSIONS	24

SECTION 1 — INTRODUCTION

1.1 GENERAL DESCRIPTION

The ATASI Series 3000 DISK DRIVES are random access storage devices with two, three or four non-removable 5¼ inch disks as storage media. Each disk surface employs one moveable head to service its data tracks and one disk surface is dedicated to continuous servo positioning data.

High performance and high unit reliability are achieved through the use of a linear voice coil and a closed loop servo positioning system. The inherent simplicity of mechanical construction and electronic controls allows for maintenance free operation throughout the life of the drive. The electronic PWA's are mounted outside the head disk area for quick and simple field serviceability.

Mechanical and contamination protection for the heads, disk and actuator are provided by a Disk Drive Module, (DDM) which is a sealed mechanical enclosure with a self contained recirculating air filtration system that supplies clean air and temperature equalization throughout the DDM.

Shock and thermal isolation are provided by the combination of a heavy duty steel chassis to which the DDM is shock-mounted, and internal isolation within the DDM.

The bottom surface of the lowest disk contains the continuous servo data, utilized to ensure precise positioning of the read/write heads.

The ATASI Series 3000 uses a ST506/4XX compatible interface.

The unit size and mountings are identical to the industry standard mini-floppy disk drives and uses the same dc voltages and connector.

KEY FEATURES:

- 30 Msec average seek time. (+3.0 Msec settling)
- Storage capacities of 19.84, 33.07 and 46.30 megabytes unformatted.
- Spare Tracks. (10 per surface)
- Dedicated disk servo surface with servo guard band.
- Dedicated landing zone.
- Patented linear motor/closed loop servo head positioning.
- Double shock isolation.
- Thermal isolation.
- Industry Standard 5¼-inch physical size and mountings.
- Same DC voltages as Standard 5¼-inch drive.
- ST506/4XX compatible interface.
- 5.0 Mbit/sec data transfer rate.

1.2 DEVICE SPECIFICATION

1.2.1 ENVIROMENTAL SPECIFICATIONS

Environmental Limits:

Operating Temperature	10° to 50° C
Non Operating Temperature	-40° to 60° C
Operating Humidity	10% to 80%
Non Operating Humidity	5% to 95%
Maximum Wet Bulb	25° C (Non-condensing)
Thermal Gradient	10° C per hour
Operating Altitude	0 to 10,000 feet
Operating Vibration	.5G at 10-500 Hz
Non Operating Shock	30Gs

Voltage Requirements:

+5VDC± 5% 1.0 Amp typical
 +12VDC±5% 4.5 Amps max (starting for 15 sec) 2.5 Amps typical
 (For more information see Figure 12)

1.2.2 RELIABILITY SPECIFICATIONS

MTBF=12,000 POH
 PM=NONE REQUIRED
 MTTR=30 Minutes
 Component Design life=5 Years

ERROR RATES:

Soft read errors=1 per 10/10th bits read
 Hard read errors=1 per 10/12th bits read*
 Seek errors=1 per 10/6th seeks
 *Not recoverable within 16 re-tries

1.2.3 PERFORMANCE SUMMARY

Model	3020	3033	3046
Capacity Unformatted (+ 10 spare Cylinders)			
Per Drive	19.84MB	33.07MB	46.30MB
Per Surface	6.61MB	6.61MB	6.61MB
Per Track	10.416KB	10.416KB	10.416KB
Capacity Formatted (+ 10 Spare Cylinders)			
Per Drive	15.60MB	26.00MB	36.40MB
Per Surface	5.20MB	5.20MB	5.20MB
Per Track	8.192KB	8.192KB	8.192KB
Per Sector	256Bytes	256Bytes	256Bytes
Sectors/Track	32	32	32
Transfer Rate	5Mbit/sec	5Mbit/sec	5Mbit/sec
Seek Time			
Track to Track	3.0ms	3.0ms	3.0ms
Average	30.0ms	30.0ms	30.0ms
Maximum	60.0ms	60.0ms	60.0ms
Settling	3.0ms	3.0ms	3.0ms
Average Latency	8.33ms	8.33ms	8.33ms
Start Time	15 Sec	15 Sec	15 Sec

NOTE: The access times specified above are typical over a large number of positionings. Due to the nature of a track following servo and some customer unique parameters they should not be used as absolute maximum values.

1.2.4 FUNCTIONAL SUMMARY

Rotation +/-1%	3600rpm	3600rpm	3600rpm
Recording max	8780bpi	8780bpi	8780bpi
Flux Density	8780fci	8780fci	8780fci
Track Density	800tpi	800tpi	800tpi
Data Cylinders	645	645	645
Tracks	1905	3175	4445
R/W Heads	3	5	7
Disks	2	3	4
Index	1	1	1

SECTION 2 — GENERAL OPERATION

2.1 Organization

There are three basic functions that are required by a Disk Drive. They are, to position the Read/Write heads over the desired track, to Write Data, and to Read Data. In the ATASI 3000 drives this is done with the following electro-mechanical assemblies:

- Read/Write/Interface PWA
- Spindle/EMA Drive PWA
- Servo Control PWA
- Spindle Drive Mechanism
- Air Filtration System
- Positioning Mechanism
- Read/Write Heads and Media

2.2 READ/WRITE/INTERFACE PWA

The READ/WRITE/INTERFACE PWA, to which all power, control and data signals are connected, provides the following functions:

- POWER reception and internal voltage regulation.
- CONTROL INPUT SIGNAL reception and Internal distribution.
- CONTROL OUTPUT SIGNAL accumulation, sequencing and transmission.
- READ/WRITE SIGNAL, bi-directional reception, conditioning and transmission.
- FAULT detection and FAULT SIGNAL generation.

2.3 SPINDLE/EMA DRIVE PWA

The SPINDLE/EMA DRIVE PWA contains a dedicated MICROCOMPUTER and is mounted directly to the bottom of the DDM mechanical enclosure. It derives its power from the R/W/INTERFACE PWA and provides the following functions:

- Power and speed control to the spindle drive motor.
- Power drive to the voice coil actuator, Electro Magnetic Actuator (EMA).

2.4 SERVO CONTROL PWA

The SERVO CONTROL PWA contains a dedicated MICROCOMPUTER and is mounted to the top cover of the DDM mechanical enclosure, and provides the following functions:

- Signal sequence control and monitoring during the power up operation.
- Receives the SERVO DATA that is read from the dedicated SERVO DISK surface by the SERVO HEAD.
- Conditions the SERVO DATA and generates POSITION SIGNALS.
- Distinguishes between STEP and BUFFERED MODE seeks. In the case of BUFFERED MODE, generate, detect and control the carriage velocity to ensure the optimum arrival at the desired cylinder.
- Continuous position control while on track.

2.5 SPINDLE DRIVE MECHANISM

A brushless DC drive motor rotates the spindle at 3600 RPM \pm 1%. The motor is thermally isolated from the baseplate to minimize the temperature transfer. The motor, spindle and disk stack are dynamically balanced to eliminate vibration. A dedicated MICROCOMPUTER provides complete digital control of the spindle rotation and permits algorithm control of motor start and stop.

2.6 AIR FILTRATION SYSTEM

The disks and read/write heads are fully enclosed in the DDM module using an integral recirculating air system with an absolute filter to maintain a clean environment. Integral to the filter is a port which permits pressure equalization with the ambient air.

2.7 POSITIONING MECHANISM

The read/write heads are mounted on a ball bearing supported linear carriage which is positioned by a linear voice coil motor, driven by the closed loop servo system.

2.8 READ/WRITE HEADS AND MEDIA

The recording media consists of a lubricated thin magnetic oxide coating on a 130 mm diameter aluminum substrate. This coating formulation, together with the low load force/low mass Winchester type heads, permit reliable contact start/stop operations. Data on each of the data surfaces is read or written by one read/write head. Each head accesses 645 data cylinders.

SECTION 3 — FUNCTIONAL OPERATION

3.1 POWER SEQUENCING

The +5 and +12 volts dc may be applied in any order. +12 volts must be applied to start the spindle drive motor. A MICROCOMPUTER monitors the disk rotation. At 3600 +/-1%, the heads will automatically recalibrate to track 00. Under normal operation, the signal -TRACK 0 will precede the signals -READY and -SEEK COMPLETE by typically less than 30 μ sec. The -READY signal is inhibited or disabled by any fault condition. The disk drive can only perform read/write or seek functions following the setting of the -READY signal. (see Figure 1 for the signal sequence).

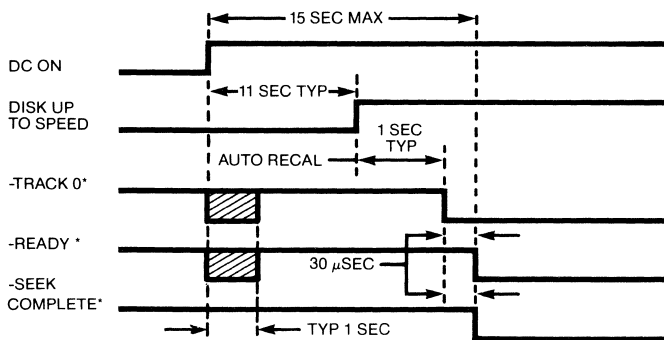

* -TRACK 0, -READY and -SEEK COMPLETE will not be present at the interface unless the drive is selected

Figure 1 POWER UP SEQUENCE

3.2 DRIVE SELECTION

Drive selection occurs when one of the -DRIVE SELECT lines is activated. Only the respective drive selected will respond to the signals from the controller interface. There is also a radial select line which permanently selects the drive (See Section 4.6).

3.3 CYLINDER ACCESSING

Read/Write head positioning is accomplished by:

- Activating the respective -DRIVE SELECT line.
- -READY condition with -SEEK COMPLETE.
- No FAULT conditions exist.
- Selecting the correct -DIRECTION.
- Pulsing the -STEP line.

Each -STEP pulse will move the heads 1 cylinder. Motion is inward or outward depending on the state of the -DIRECTION IN signal. A high state indicates inward toward the spindle and a low indicates outward from the spindle. Seeks can be done in 3ms steps, or in the buffered mode (see 4.1.4).

3.4 HEAD SELECTION

Read/write heads may be selected by placing the respective binary address on the -HEAD SELECT lines.

3.5 READ OPERATION

Reading data is accomplished by:

- -DRIVE SELECT.
- Inactive -WRITE GATE.
- No FAULT conditions.
- Disk drive is -READY and -SEEK COMPLETE.
- -HEAD SELECT for the appropriate head.
- Present MFM READ DATA to the host controller.

3.6 WRITE OPERATION

Writing data is accomplished by:

- -DRIVE SELECT.
- Drive is -READY and -SEEK COMPLETE.
- -HEAD SELECT for the appropriate head.
- No FAULT conditions.
- Activate -WRITE GATE and receive MFM WRITE DATA from the host controller.

SECTION 4 — ELECTRICAL INTERFACE

The disk drive interface is divided into three categories, each of which is physically separate.

- CONTROL SIGNALS
- DATA SIGNALS
- DC POWER

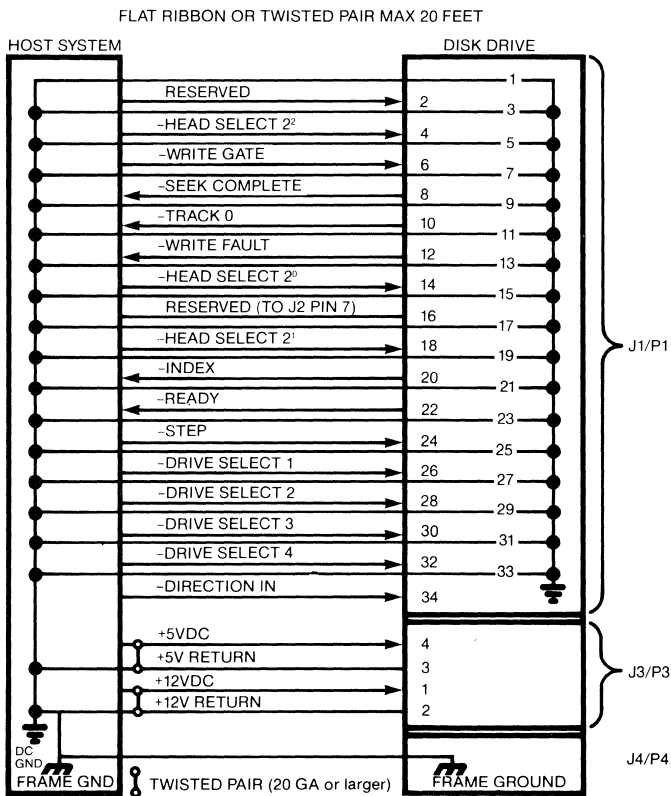

Figure 2 CONTROL SIGNALS

8

All control signals are digital (open collector TTL) and either provide signals to the drive from the host controller or to the host controller from the drive via connector J1/P1. The data transfer signals are differential and are connected via connector J2/P2. DC power utilizes connector J3/P3. The one exception to the above is -DRIVE SELECTED which is a digital signal, but is transmitted via J2/P2. Figures 2 through 4 show connector pin assignments and interconnection of cabling between the disk drives and the host controller.

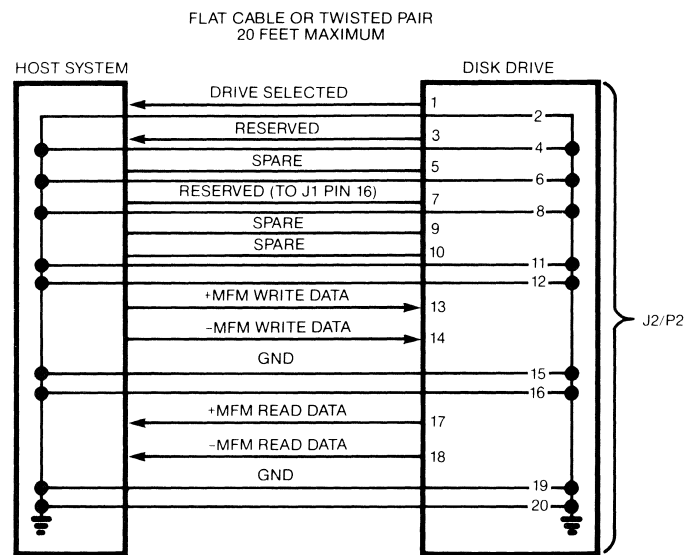
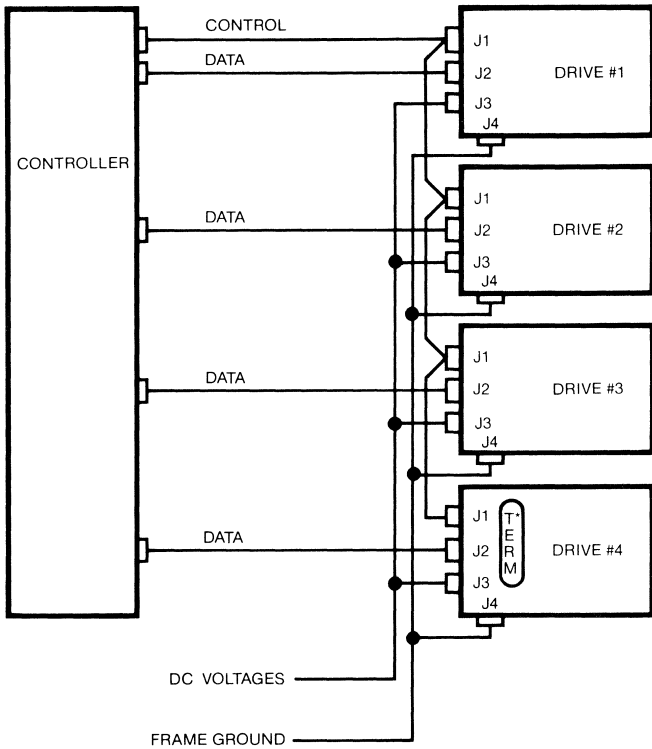

Figure 3 DATA SIGNALS

9



* The last or only drive in the control cable string must have the terminator resistor pack installed. All other drives must have their terminators removed.

Figure 4 TYPICAL CONNECTION, 4 DRIVES

4.1 CONTROL INPUT LINES

The control input signals are of two types: Those to be multiplexed in a multiple drive system and those intended to do the multiplexing. The multiplexed lines are -WRITE GATE, -HEAD SELECT, -STEP and -DIRECTION IN. The multiplexer is -DRIVE SELECT. The active state for all of these lines is low or 0-+7VDC. The inactive state is high OR +2-+5VDC. The control input lines require the following specifications. (see Figure 5 for recommended circuitry).

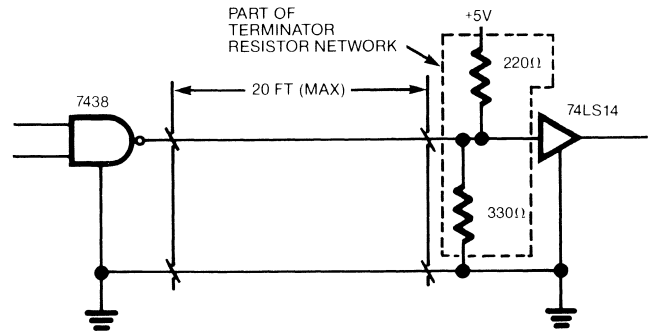

Figure 5 CONTROL SIGNAL RECEIVER/DRIVER COMBINATION

4.1.1 -WRITE GATE

This line, when active, enables write data to be written on the disk. The inactive state enables data to be read from the disk. The inactive state also enables seek operations.

4.1.2 -HEAD SELECT 2⁰, 2¹, 2²

These lines provide a means to select R/W heads in a binary coded sequence. When all -HEAD SELECT lines are inactive, HEAD 0 is selected. When the drive is not selected, R/W heads are deselected. An illegal head address will deselect all heads.

4.1.3 -DIRECTION IN

This signal defines the direction of the carriage and R/W head movement when the -STEP line is pulsed. An active -DIRECTION IN defines a seek toward the spindle. An inactive -DIRECTION IN defines a seek away from the spindle. (see Figures 6A and 6B for signal timing).

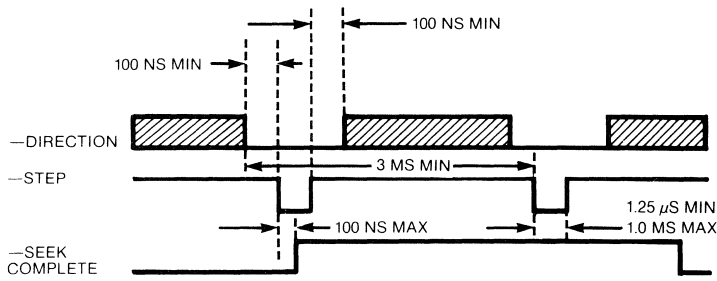

FIGURE 6A STEP MODE TIMING (NORMAL)

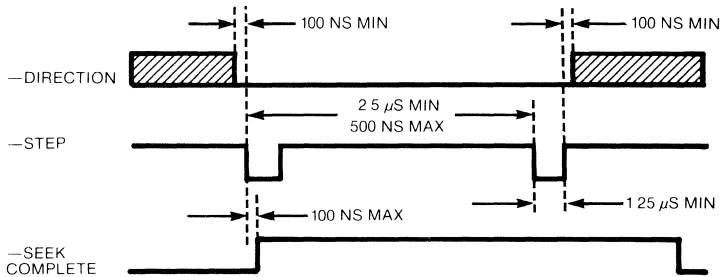

FIGURE 6B STEP MODE TIMING (BUFFERED)

4.1.4 -STEP

This signal causes the R/W heads to move in the direction indicated by DIRECTION IN. There are two modes of STEP operation, NORMAL and BUFFERED. In the NORMAL MODE the -STEP pulses may occur at intervals not less than 3 msec. The width of the pulses may range from 1.25 μsec to 1.0 msec. In the BUFFERED MODE the -STEP pulses can occur at intervals from 2.5 μsec to 500 μsec. The minimum pulse width in BUFFERED MODE is 1.25 μsec (See Figures 6A and 6B for timing).

4.1.5 -DRIVE SELECT 1-4

This signal, when active, enables the respective drive interface signals to communicate with the host controller. Addresses are customer selectable internal to the drive via S1-4 on the READ/WRITE/INTERFACE PWA. (see Figure 7 for jumper locations).

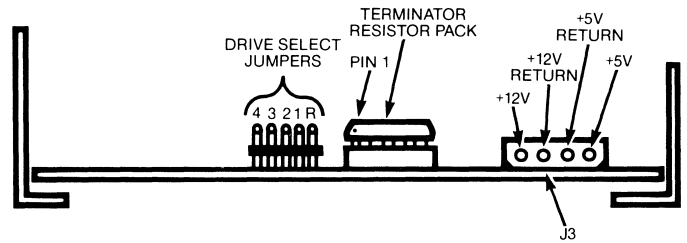

Figure 7 SELECT JUMPER, TERMINATOR AND J3 LOCATIONS

4.2 CONTROL OUTPUT LINES

The control output lines indicate the operational status, timing and functional response of the disk drive. These signals are enabled to the host controller, only while the drive is selected. (see 4.6 for the exception).

4.2.1 -SEEK COMPLETE

This signal becomes active when the R/W heads have settled on the desired cylinder at the end of a SEEK. READ or WRITE operations may not be initiated until -SEEK COMPLETE is true. -SEEK COMPLETE will go inactive within 100 nsec after the leading edge of a -STEP pulse, or the first in a series of -STEP pulses, or if +5 VDC or +12 VDC are lost momentarily.

4.2.2 TRACK 0

This signal becomes active when the disk drive's R/W heads are positioned at TRACK 0, the outermost data track.

4.2.3 -WRITE FAULT

This signal becomes active when one of the following conditions exists in a selected disk drive:

- (a) -WRITE GATE true and NO WRITE CURRENT.
- (b) WRITE CURRENT present without -WRITE GATE.
- (c) Multiple heads are selected.
- (d) When a valid selected head is shorted or open
- (e) When -WRITE GATE is active with NO WRITE DATA

-WRITE FAULT is latched in the drive and can be cleared by a power down or deselection of the drive

4.2.4 -INDEX

This signal is presented to the host controller from a selected disk drive once for each revolution of the disk, and represents the beginning of a track. (see Figure 8 for timing).

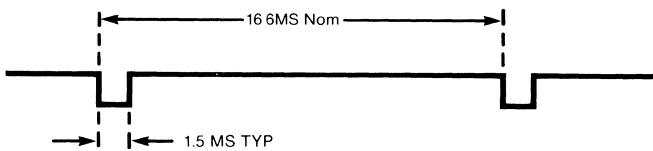

NOTE The only valid way to capture index is on the leading edge

Figure 8 INDEX TIMING

4.2.5 -READY

This signal in combination with -SEEK COMPLETE indicates that the selected disk drive is READY to READ, WRITE or SEEK.

4.3 DATA TRANSFER LINES

These DATA TRANSFER LINES are DIFFERENTIAL in design, consisting of two pairs of balanced signals used to transfer MFM DATA to and from the selected disk drive. (see Figure 9 for recommended circuitry).

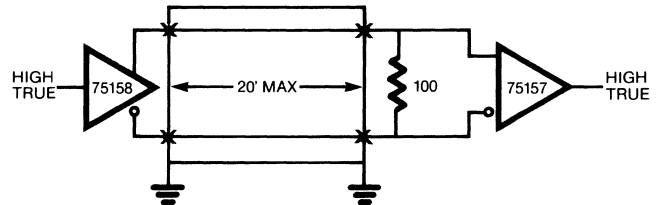

Figure 9 DATA LINE DRIVE/RECEIVER COMBINATION

4.3.1 +/-MFM WRITE DATA

These two differential MFM (Modified Frequency Modulation) signal lines define the code to be written on the track. The transition of +MFM WRITE DATA going more POSITIVE than -MFM WRITE DATA causes a transition, or flux reversal on the disk by the selected head. To ensure data integrity at the error rate specified, the WRITE DATA transmitted by the host controller must be PRE-COMPENSATED from cylinders 320 through 645. Optimum pre-comp of both early and late data is 12 nsec. (see Figure 10A for MFM ENCODING and Figure 10B for WRITE PRE-COMP patterns. All patterns not represented in Figure 10B are written on-time).

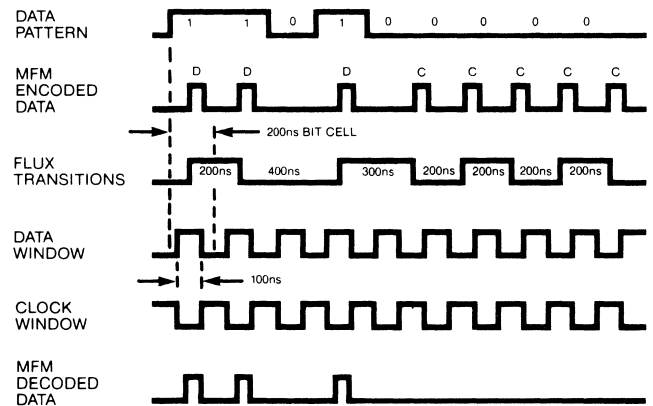

Figure 10A MFM ENCODING

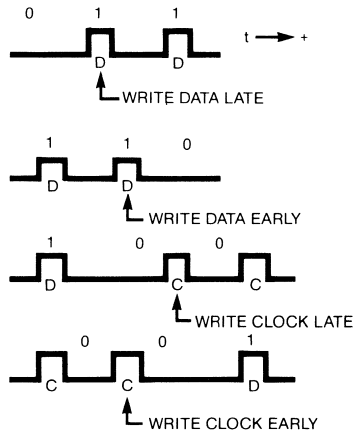

Figure 10B WRITE PRE-COMPENSATION PATTERNS

4.3.2 +/- MFM READ DATA

The transitions, "DATA" sensed by the selected head from a pre-recorded track are transmitted to the host controller as MFM READ DATA. The transition of +MFM READ DATA going more positive than -MFM READ DATA indicates the sensing of a flux reversal on the disk by the selected head.

4.3.3 READ/WRITE TIMING

READ and WRITE functions require proper signal sequencing to ensure DATA INTEGRITY. (See Figure 11 for proper signal timing).

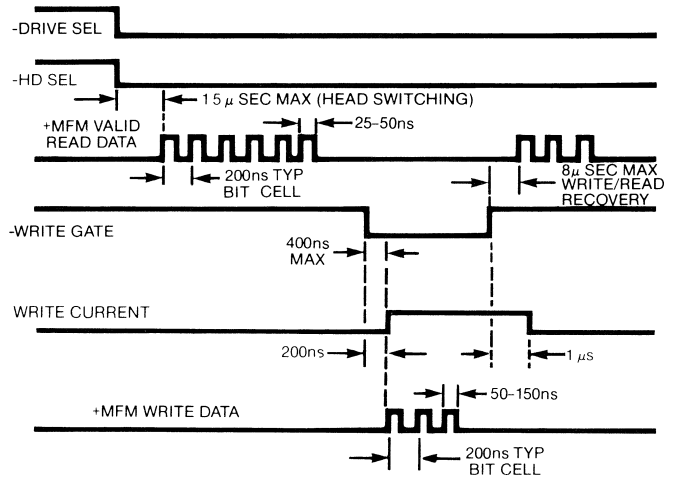

Figure 11 READ/WRITE DATA TIMING

4.4 -DRIVE SELECTED

The -DRIVE SELECTED line becomes true when the associated -DRIVE SELECT matches the PHYSICAL ADDRESS of the disk drive, or the radial option is selected.

4.5 POWER INTERFACE

The voltages required to operate the drive are +5VDC and +12 VDC (See Figures 12 and 13 for more detail on the current requirements.)

VOLTAGE	MAX START	TYP START	MAX SEEK-ING	TYP SEEK-ING	MAX STEADY STATE	TYP STEADY STATE	MAX RIPPLE P-P
+5	1.5 AMP	1 AMP	1.5 AMP	1 AMP	1.5 AMP	1 AMP	50mV
+12	4.5 AMP	3.8 AMP	3 AMP	2.5 AMP	2 AMP	1.5 AMP	50mV

Figure 12 CURRENT REQUIRMENTS

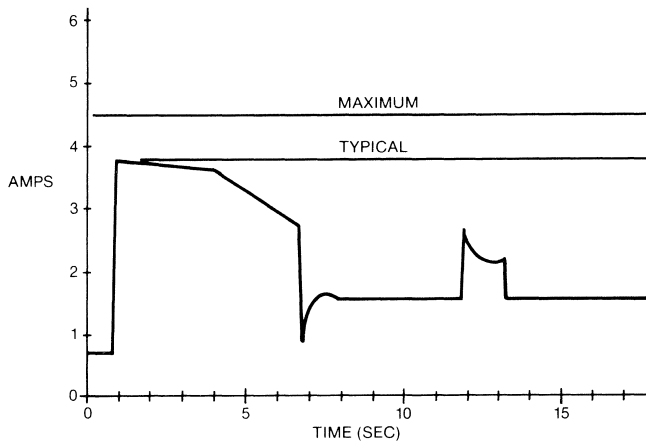

Figure 13 +12V STARTING CURRENT

4.6 CUSTOMER OPTION

A RADIAL interface option is available and is CUSTOMER SELECTABLE by placing a jumper in LOCATION "R" on the READ/WRITE/INTERFACE PWA. With this jumper installed, the interface output signals are enabled at all times. The DRIVE SELECTED "LED" will illuminate only when the drive receives a valid -DRIVE SELECT, ie, in this case, there must be two jumpers installed, one on "R" and one on 1, 2, 3, or 4. (See Figure 7 for jumper location)

SECTION 5 — PHYSICAL INTERFACE

The interface between the disk drive and the host controller consists of four connections:

- J1 — CONTROL SIGNALS
- J2 — READ/WRITE SIGNALS
- J3 — DC POWER
- J4 — FRAME GROUND

(see Figure 14 for connector locations).

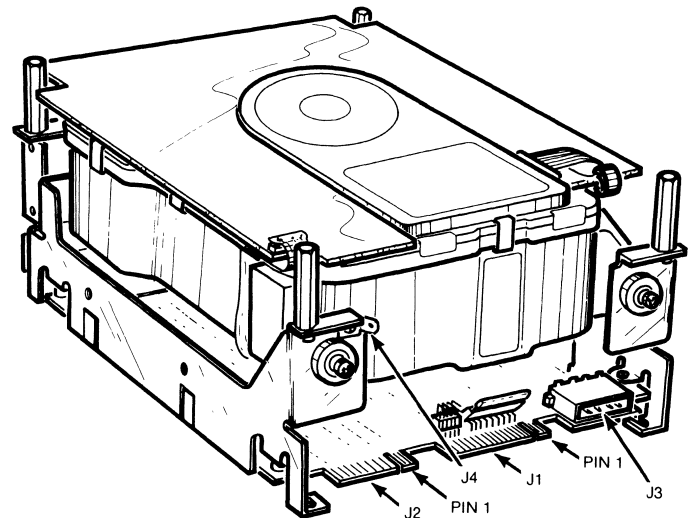

Figure 14 CONNECTOR LOCATIONS

5.1 J1/P1 CONNECTOR—CONTROL SIGNALS

Connection to J1 is through a 34 pin PWA edge connector. The dimensions for this connector are shown in Figure 15. The pins are numbered 1 through 34 with the even pins on the solder side of the PWA. A key slot is provided between pins 4 and 6. The recommended mating connector for J1 is AMP Ribbon connector p/n 88383-3. All odd pins are ground.

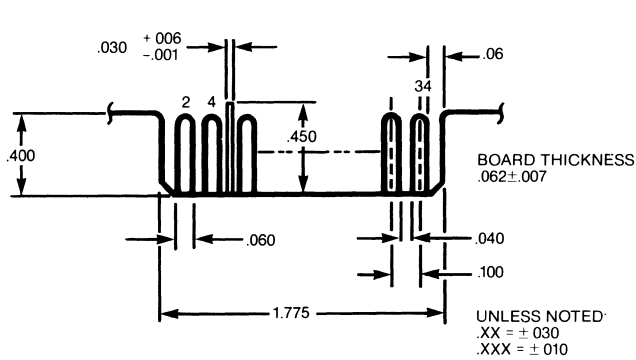

Figure 15 J1 CONNECTOR DIMENSIONS

5.2 J2/P2 CONNECTOR—DATA SIGNALS

Connection to J2 is through a 20 pin PWA edge connector. The dimensions for the connector are shown in Figure 16. The pins are numbered 1 through 20, with the even pins located on the solder side of the PWA. The recommended mating connector for J2 is AMP p/n 88737-6. A key slot is provided between pins 4 and 6.

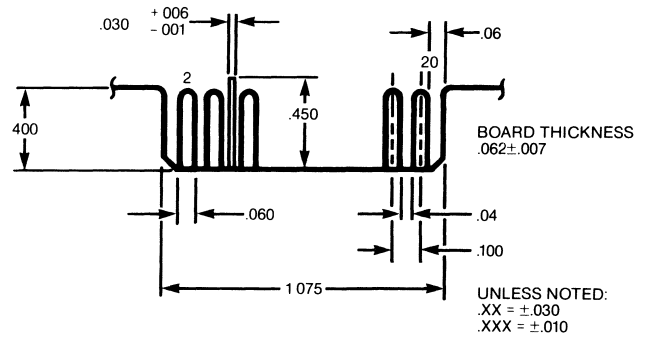
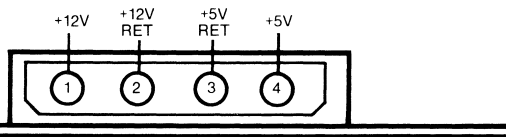

Figure 16 J2 CONNECTOR DIMENSIONS

5.3 J3/P3 CONNECTOR—DC POWER

DC power connector J3 is a 4 pin AMP MATE-N-LOCK connector, AMP p/n 350211-1 and is mounted on the component side of the PWA. The recommended mating connector for J3 is AMP p/n1-480424-0, J3 pins are numbered as shown in Figure 17.

CAUTION: Damage will occur to the drive if the +5V and +12V connections are reversed.



NOTE: This is the Drive end of the connector

Figure 17 J3 CONNECTOR LAYOUT

5.4 J4/P4 FRAME GROUND

Recommended mating connector AMP 62187-1.

NOTE: DC GROUND is isolated from FRAME GROUND. Frame ground connections are very important to reduce the effects of ground loops and noise which can effect DATA INTEGRITY.

SECTION 6 — PHYSICAL SPECIFICATIONS

6.1 MOUNTING ORIENTATION

Recommended mounting is either vertical on either side or horizontal. The only PROHIBITED MOUNTINGS are INVERTED HORIZONTAL or INCLINED such that the actuator is accessing on a NON-LEVEL PLANE. In final mounting, it is IMPORTANT to ENSURE that the SHOCK MOUNTS that ISOLATE the CHASSIS from the FRAME are NOT RESTRICTED.

6.2 MOUNTING HOLES

Eight standard mounting holes are provided, four on the bottom and two on each side. The size and location of the mounting holes are identical to the standard mini-floppy drive. Additional chassis attachment points are provided near the corners of the top and bottom surfaces which may be used for mounting or stacking of drives. (See Figure 18 for dimensions)

6.3 PHYSICAL DIMENSIONS

Height 3.25 inches, width 5.75 inches and depth 8.00 inches are identical to the standard mini-floppy, allowing a direct physical replacement. (See Figure 18 for dimensions).

6.4 SHIPPING REQUIREMENTS

During shipping or transporting, the R/W heads are positioned at the LANDING/SHIPPING ZONE. This is accomplished automatically by removing power to the drive.

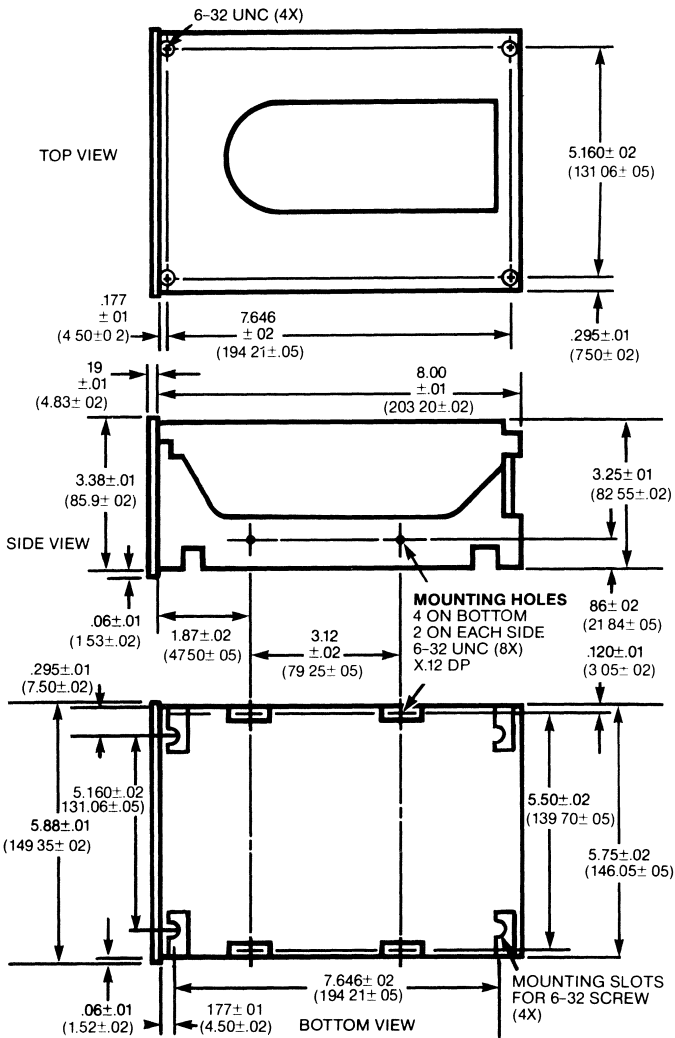

Figure 18 — MOUNTING DIMENSIONS

SECTION 7 — SURFACE DEFECTS

As shipped, any area which is considered MARGINAL for DATA RECORDING or which has a PERMANENT DEFECT, will be indicated in a listing of the defects in terms of CYLINDER, HEAD and the NUMBER OF BYTES from INDEX. This listing will be supplied with each unit shipped. These areas should not be used for data handling even though they may appear to be good.

Other ManualsLib Projects



www.manualslib.com



www.manualslib.de



www.manualslib.es



www.manualslib.fr



www.manualslib.nl



www.manualslib.mx



www.manualslib.tech 30+ Languages